

PALMER INDUSTRIES

Towel Shelf Instructions

Important: If washstand is cut in width or depth on site, this shelf will not fit. Please return shelf to Palmer for modification.

Alignment of Shelf Supports

It is important to set the horizontal shelf supports parallel with each other, such that the width between these tubes is exactly equal, both front and rear. Additionally, these **tubes must be level**. This will set the proper inside dimensions of the shelf supports, and ensure that the shelf fits and mounts properly. See diagram below.

Check that the screws that secure the four brackets to the shelf are tight and did not come loose during shipping, and ensure the brackets are straight. The shelf hangs on these four brackets, suspended from the shelf supports.

Check that the shelf has not twisted during shipment by laying the shelf on a flat surface such as a counter, and noting any excessive rocking at the corners. If necessary, twist may be removed by gently applying pressure to the shelf opposing the twist.

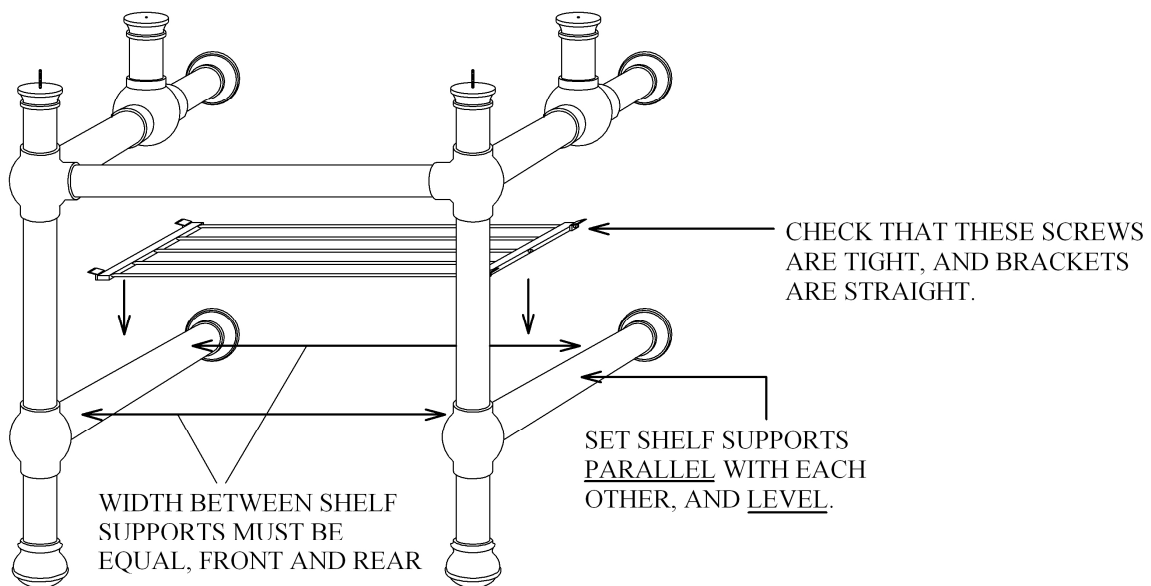

LS2B SHOWN FOR REFERENCE ONLY

Contact **Palmer Industries** at 800-398-9676 for any questions or parts. Rev 01/10.

PALMER INDUSTRIES

Towel Shelf Instructions (cont.)

If the gap between any of the shelf brackets and the shelf support tube is too great, causing the bracket to not grip the tube adequately, shims can be installed between the shelf bracket and the shelf end rod, as shown below.

The shims will reduce this gap, by moving the bracket outward toward the shelf support tube. Remove the #10-32 flat-head screw and shelf bracket, and re-install with shims as required, passing the screw through the shims.

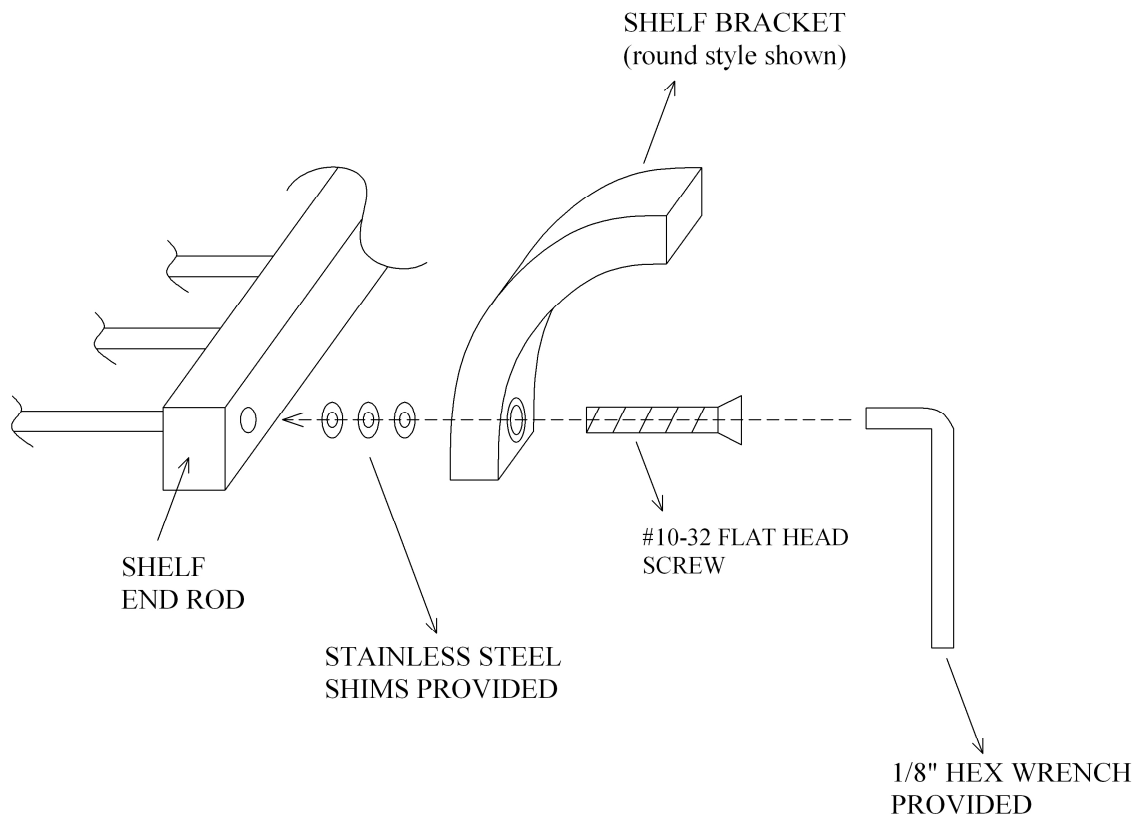

Contact **Palmer Industries** at 800-398-9676 for any questions or parts. Rev 01/10.